

1967-70 FORD MUSTANG POWER BRAKE KIT (PBU9007MC)

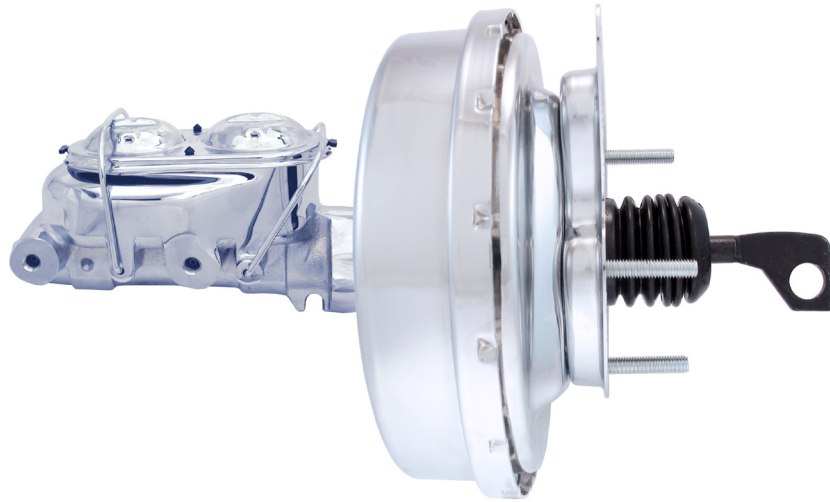

(chrome version shown)

WARNING:

This kit is designed for 67-70 Mustangs. This product is intended for people who want to convert from a manual brake car to a power brake car. In order to use this kit, one will need to make significant modifications to the car. The modifications will involve the steel brake lines, the firewall, the brake pedal arm and bracket.

NOTE:

Before operating the vehicle after installation test the function of the brakes under controlled conditions. Make several stops in a safe area from low speed and gradually work up to normal speeds. **DO NOT DRIVE WITH UNTESTED BRAKES!** Always utilize safety restraints when operating the vehicle.

1967-70 FORD MUSTANG POWER BRAKE KIT (PBU9007MC)

PLANNING

Use this chart to determine the required steps depending on if your vehicle was originally manual or power brake:

	Manual	Power	Section
Need Fire Wall Template	Yes	No	1
Brake Pedal Length Check	Yes	Yes	2
Relocate Pedal Hole Position	Yes	No	3



Step 1:

SAFETY 1st: chock your wheels, set your parking brake, and disconnect the battery.

Remove the following components from your car:

Tech Tip: Prior to disassembly spray the nuts and bolts that you will be removing with a penetrating oil. (Also disconnect the battery to eliminate the risk of draining the battery or an electrical short.)

1. Remove the old master cylinder from your car by first disconnecting the brake lines to the master cylinder. Next, remove the push rod from the brake pedal by removing the bolt located at the top of the pedal. Then remove the old master.

2. Now remove the original brake pedal.

* If your car was not originally a power brake car, then you must remove the bracket and drill a hole to accommodate the new hole position for a power brake pedal arm.

3. Check for a positioning hole in the top of the pedal support. Most cars will have a 3/8" diameter hole on the top, towards the front of the car. If the hole is missing you must remove the pedal support and drill a 3/8" diameter hole in the proper location.

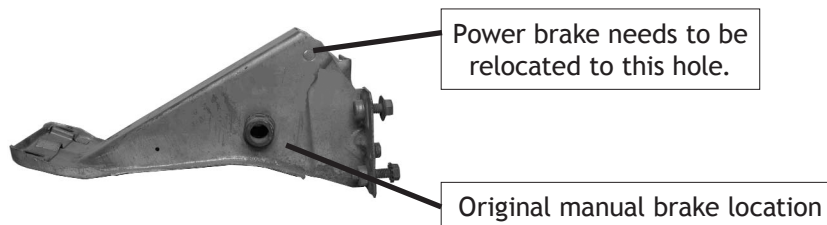

Picture of an original 67-70 Mustang pedal support. To install power brakes you must move the pedal pivot point from the manual brake location to the top hole in the pedal support. The hole is 3/8" in diameter. If the hole is missing you must remove the pedal support and drill a 3/8" diameter hole in the proper place.

1967-70 FORD MUSTANG POWER BRAKE KIT (PBU9007MC)

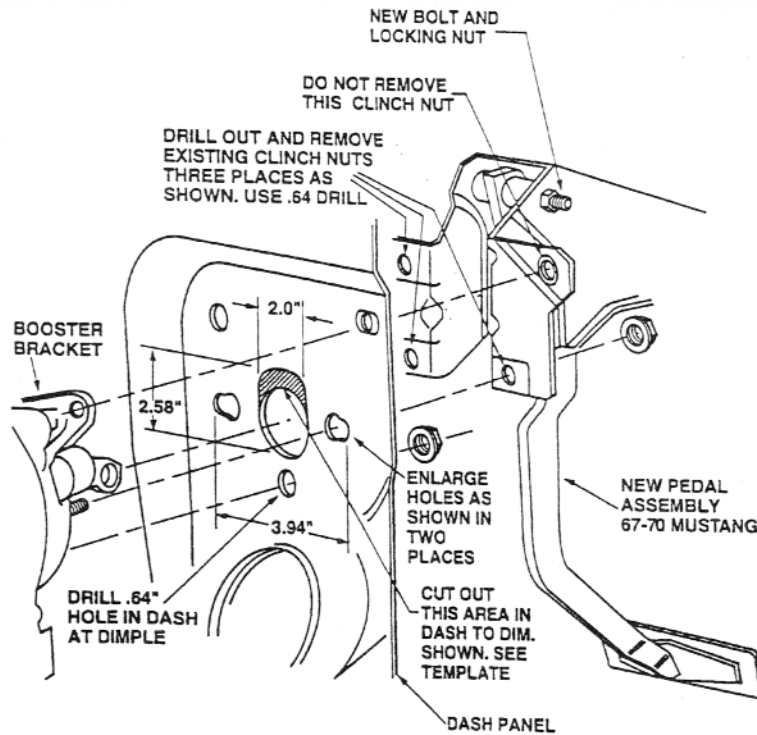

1967-70 FORD MUSTANG FIREWALL

PART 2:

Things to prepare before assembly of the new booster & master kit.

1. Remove the new master cylinder from the booster assembly.
2. Bench bleed the new master cylinder to remove all the air. If all the air is removed from the master, then it will be difficult to push the piston in.

How to bench bleed:

Remove the master from the booster and place in a vice. (Be sure to clamp onto the mounting ear and not the cylinder.)

Install the proper size plugs in the outlet ports of the master.

Fill the master cylinder to the full line with brake fluid.

Use a rounded end rod or a phillips head screw driver and push the piston in repeatedly until no bubbles are visible.

NOTE: This may take a minute or two of continuous pumping!

1967-70 FORD MUSTANG POWER BRAKE KIT (PBU9007MC)

PART 3:

Installation of booster & master components:

1. Slide the pedal up into the pedal support and insert the bolt through the top hole of the support. Do not over-tighten the nut with nylon insert. The pedal must be free from binding. (If your car originally had a power brake system you will use your original pedal. If it was a manual brake system, then you will reuse the original bolt in the power Brake hole location.)
2. Now drill new holes corresponding to the booster mounting studs. Also, open up the area above the large hole in the firewall for added clearance using the gasket as a template (As shown in the diagram). Note: Warranty is void if sufficient clearance is not provided.
3. Install the booster to the firewall using the supplied hardware. Then attach the booster push rod to the pedal (As shown in the diagram).
4. Connect the vacuum fitting and the hose to either the intake manifold or to the rear of the carburetor. Make sure that the vacuum source on the carburetor is manifold vacuum and not timed vacuum. Note: The engine must provide a minimum of 18" of vacuum for the booster to work effectively.
5. Reconnect the battery and start the engine. Test the brakes. If the pedal goes to the floor or is very spongy then bleed the system once again.
6. Test drive the car in a safe location before driving.

Fire Wall Template

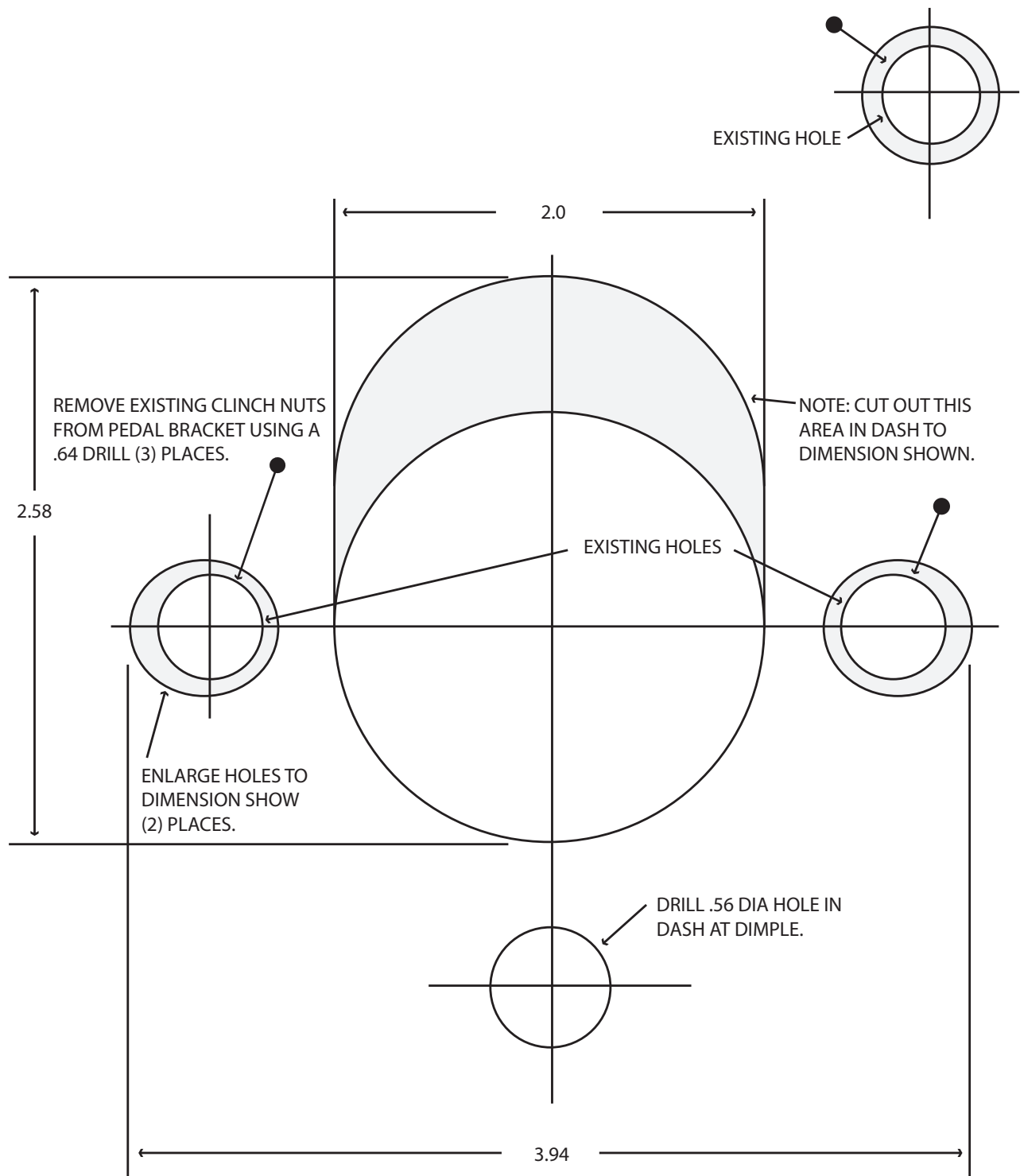

This template is used to modify the fire wall when converting from manual brakes to factory type power brake booster on 67-70 Mustangs and Cougars. Most important thing is the big hole for the booster must be raised up from the original master cylinder hole position.